

GCT 200 HSI-A FLOOR DRAIN SKU:160-001-A000

Adjustable (telescopic) stainless steel floor drain (gully) for tiled flooring in commercial kitchens, restaurants, supermarkets and food processing areas, etc. For applications with liquid membrane waterproofing systems.

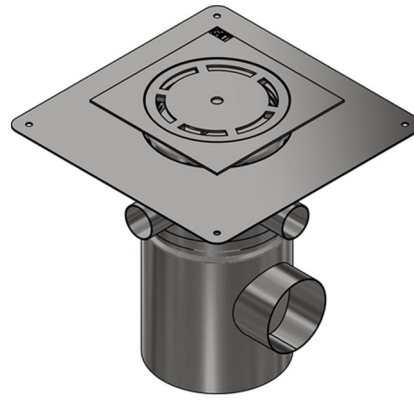

Specification

Standard (RSA): SANS 51253-1
Standard (EN): EN 1253-1
Floor: Tiles
Material (EN): 1.4301 (304) or 1.4404 (316)
Max flow (l/s): 2.95
Odour trap: Yes, integral, tamper-proof
Water seal height (mm): 50
Solids basket: Yes
Solids basket volume (l): 0.62
Surface finish: Pickled and passivated, polished
Membrane type: Liquid membrane
Adjustable: Yes
Height adjustment (mm): 3 to 40
Load class: 300KG (K3)
Number of screws: 2 (odour trap)
Gasket: Yes
Gasket material: NBR
Number of inlets: 1 to 4
Inlet/s diameter (mm): 50.8
Outlet direction: Horizontal
Outlet diameter (mm): 110
Minimum height (mm): 374
Maximum height (mm): 411
Body diameter (mm): 202
Overall dimensions (mm): 400 l X 400 w X 374 h
Weight (kg): 8.0

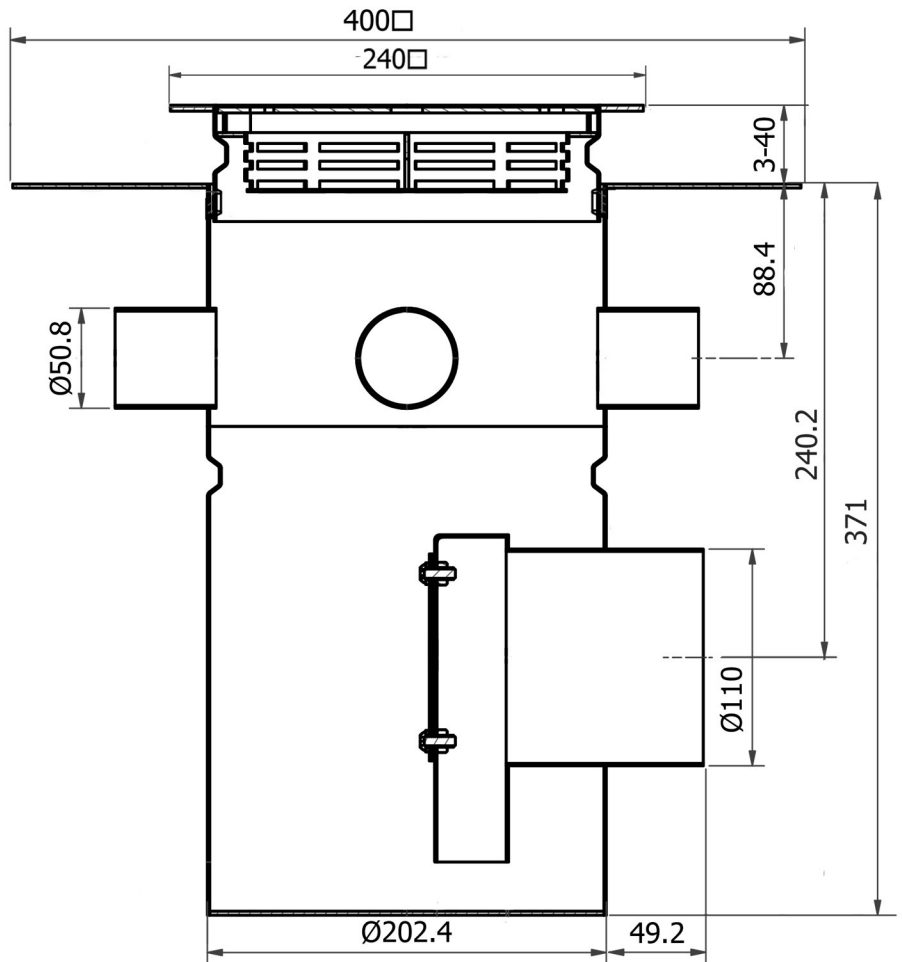

Order Sheet:

Please mark option/s in each box with an X. * (asterisk) indicates special order. If no options are selected the product is supplied as standard.

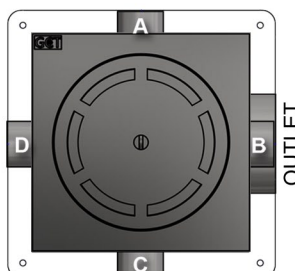
MATERIAL	LID TYPE	FLANGE SHAPE	FLANGE/ LID THICKNESS	SIDE INLET/S POSTION/S
select one X	select one X	select one X	select one X	select one to four X
<input type="checkbox"/> 304 <input type="checkbox"/> 316*	NOT APPLICABLE	NOT APPLICABLE	NOT APPLICABLE	<input type="checkbox"/> A <input type="checkbox"/> B <input type="checkbox"/> C <input type="checkbox"/> D 

Qty:	Name:	Signature:	Date:	Company:	PO no:
------	-------	------------	-------	----------	--------