

# GCT-PE SUPERCEPTOR 15™ Class II

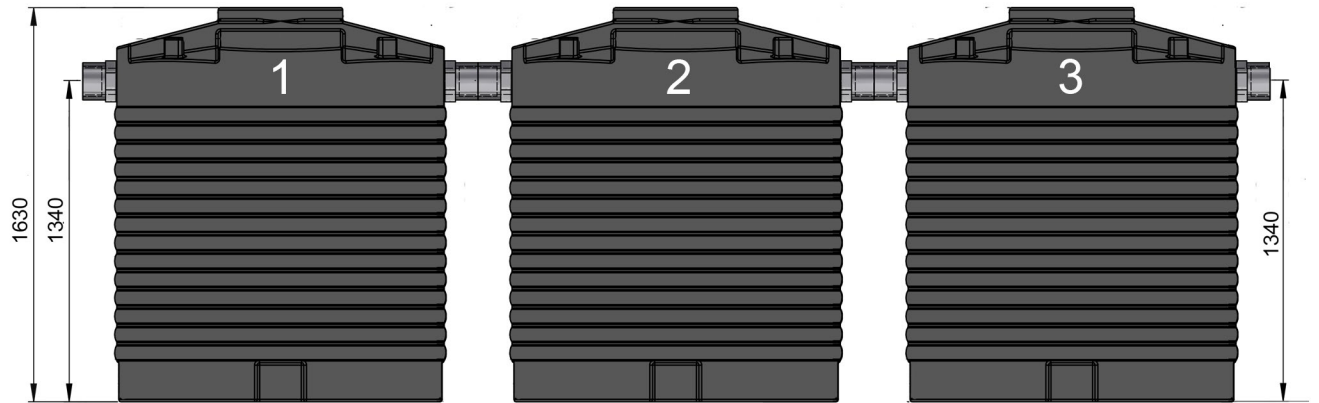

## GCT-PE Superceptor 15™ Class II Oil-Water Separator Features

### Class II gravity separator for separation of all free/non-emulsified oils

- Manufactured from high grade LLDPE, SG 1.6
- One (1) sludge tank [Tank 1]
- Two (2) gravity separation tanks [Tanks 2 and 3]
- Auto-shut-off valve by outlet (Optional)
- Three (3) easily accessible 450mm diameter covers
- Suitable for below ground or free-standing installations
- Designed in accordance with SANS 50858-1 & 2

**Flow Rate:** 15L/sec (SANS 50858-1 & EN 858-1, 100PPM, Class II Separator)

**Total Liquid Capacity:** 5500L

**Optimal Oil Storage Capacity:** 400L

**Max Sludge Capacity:** 3000L

**Net Weight:** ≈ 135KG

### General Applications:

Forecourts, petro-chemical plants, fuel depots & substations etc

