

GCT-IND 200VBD

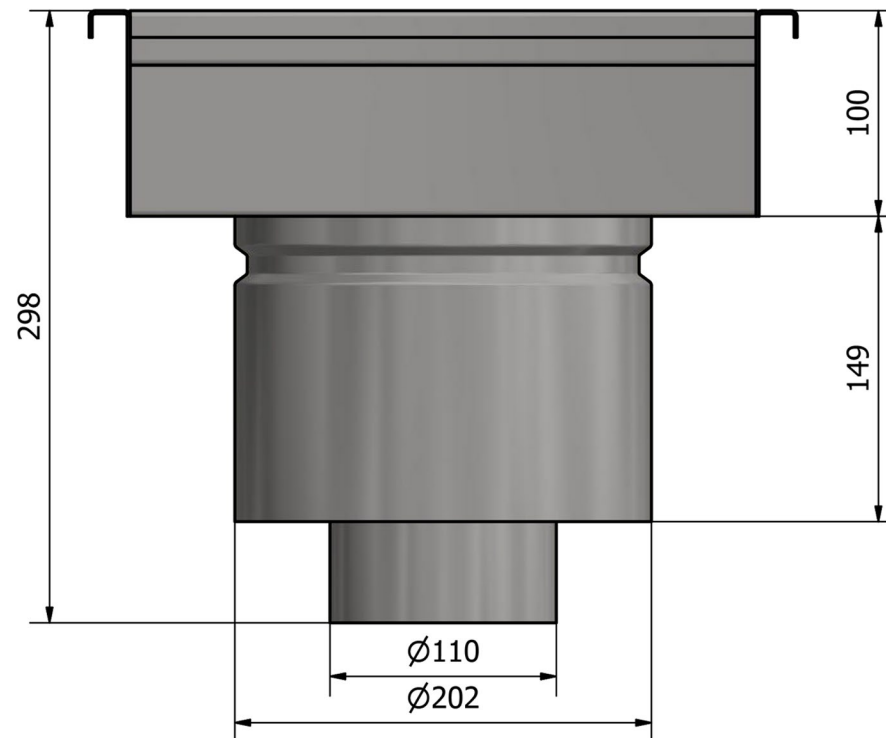
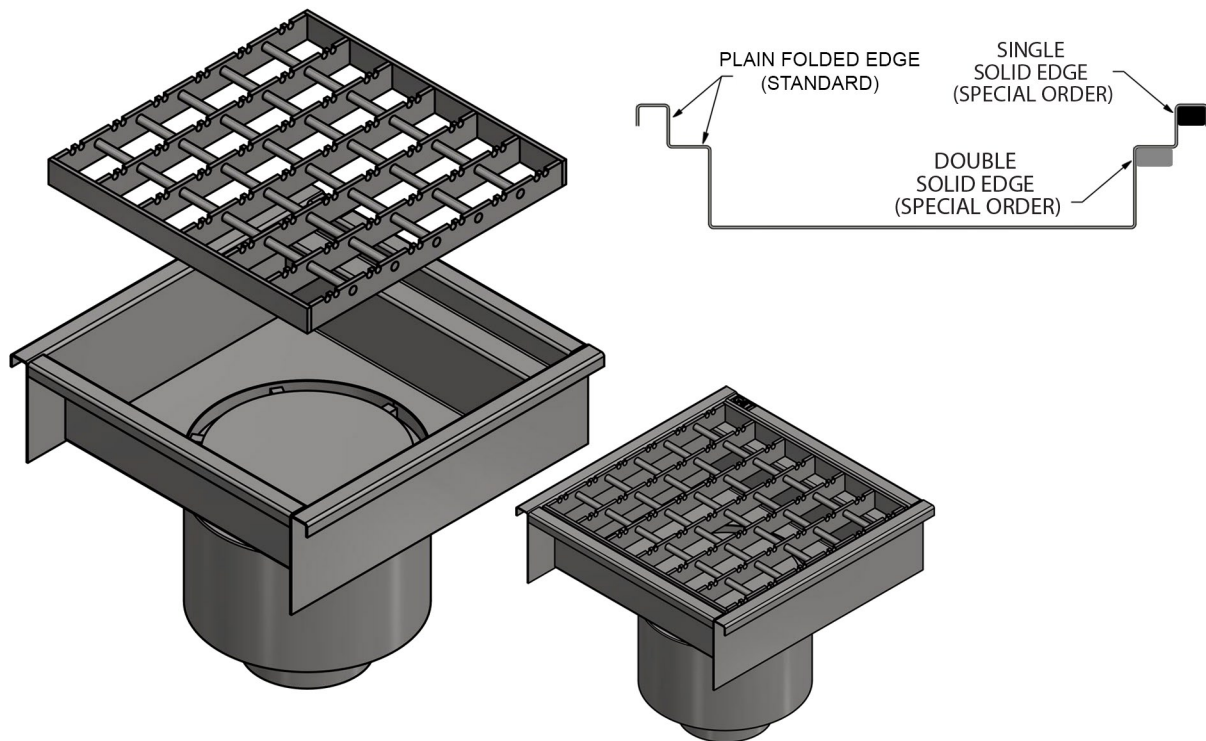

GCT-IND 200VBD Floor Drain

Features

- Manufactured from 304 stainless steel (316 on special order)
- Removable non-slip grating
- Removable tamper-proof water seal assembly
- Compatible with standard plumbing fittings
- SANS 51253-1/ EN 1253-1 compliant 50mm water seal
- Compatible with tiled and epoxy floors
- Fully pickled/ passivated body
- Vertical (bottom) outlet pipe
- Removable silt basket
- Alternative lid option

Flow Rate: 5.6L/sec

Load Class: L15 (15 kN) [Standard]

R50 [Special Order]

M125 [Special Order]

N250 [Special Order]

Net Weight: 9.1KG

General Applications:

Food processing plants, commercial & industrial kitchens etc

For applications where heavier loads/ higher flows are expected

ALPHA LID
(STANDARD)

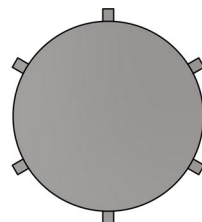

BETA LID
(SPECIAL ORDER)

