

# GCT-IND 10L/s/UG

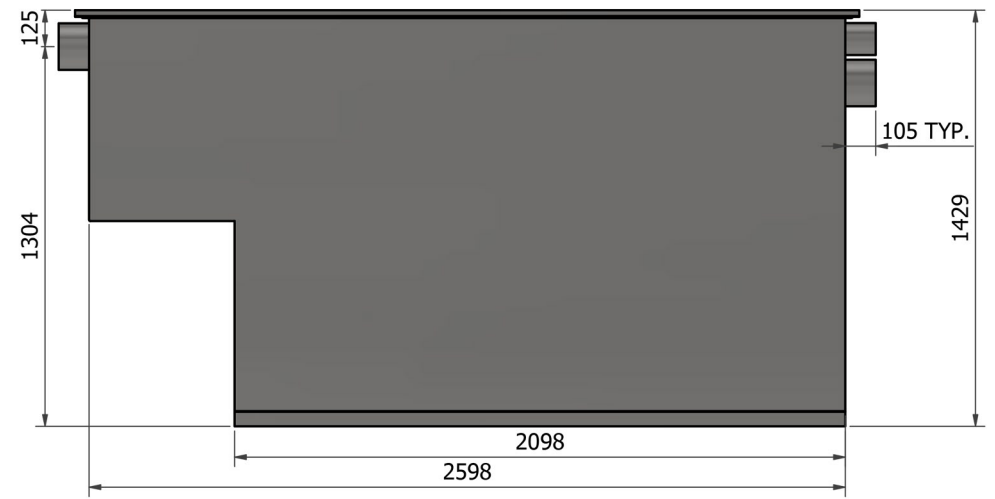
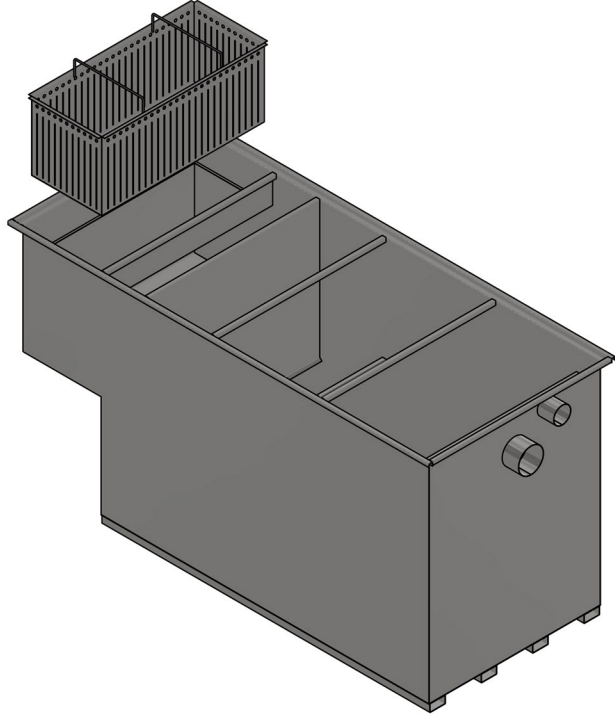

## GCT-IND 10L/s/UG Underground Grease (Fat) Trap

### Features

- Manufactured from 304 stainless steel (316 on special order)
- Separated sludge trap & grease trap
- Slotted basket strainer for easy removal of solids
- Fully accessible outlet pipe via inspection cover
- Compatible with standard plumbing fittings
- Chamber vent pipe to prevent airlocking
- Smooth surfaces to prevent bacteria build up and promote ease of cleaning
- Suitable for below ground installations
- SANS 10252-2 compliant

**Flow Rate:** 10L/sec

**Max Grease Capacity:** ≈ 425KG

**Net Weight:** 302KG

### General Applications:

Hotels, hospitals, food processing plants, commercial & industrial kitchens etc

**To be used in conjunction with the GCT-IND 10M manhole cover**

