

# GCT 200HA

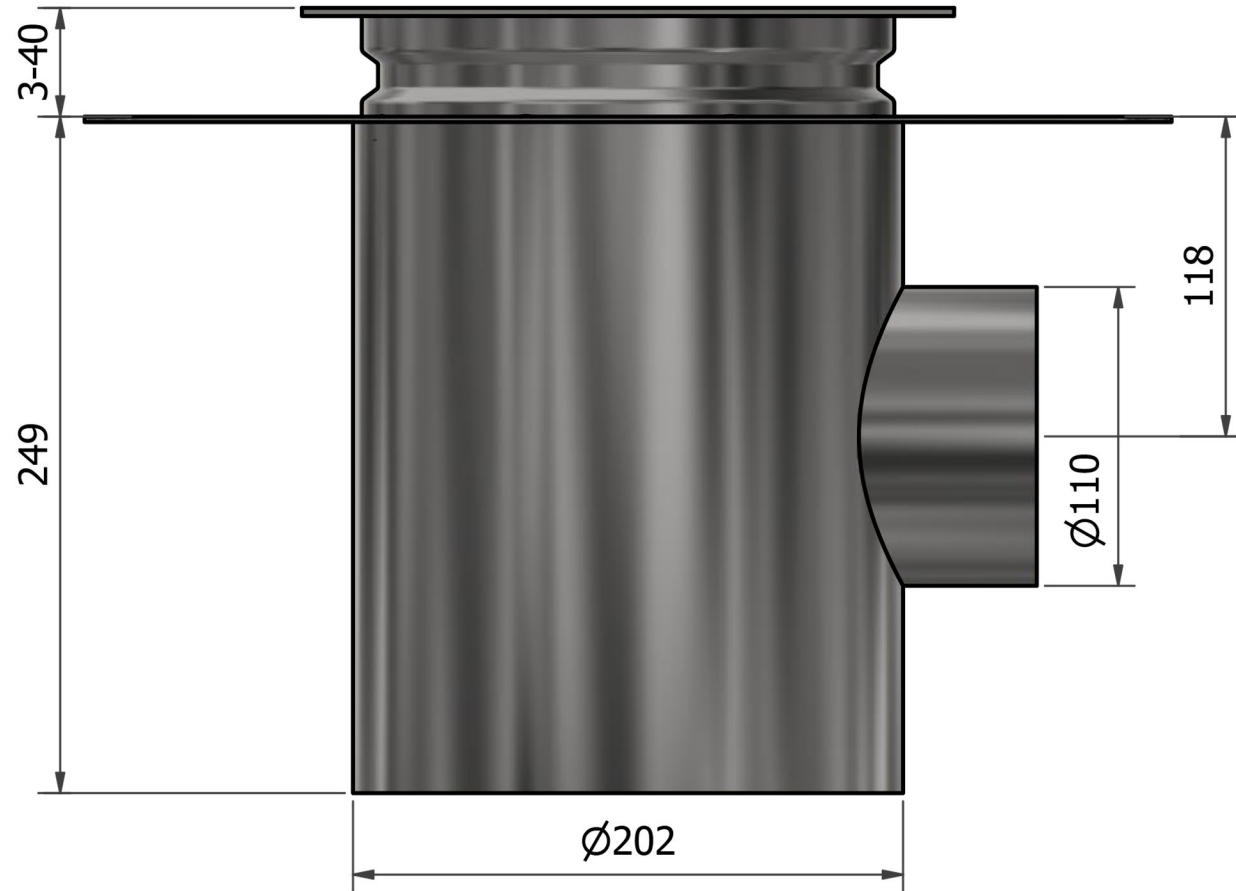
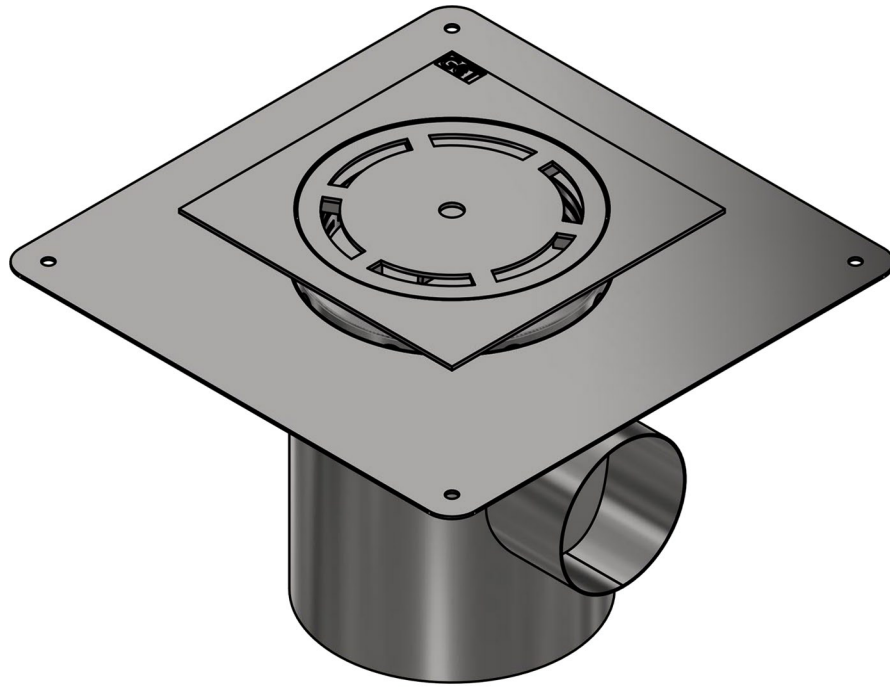

## GCT 200HA Adjustable Floor Drain

### Features

- Manufactured from 304 stainless steel (316 on special order)
- SANS 51253-1/ EN 1253-1 compliant 50mm water seal
- Friction lock 3 - 40mm height adjustment
- Adhesive bonding flange for waterproofing
- Special design allows for seepage drainage
- 360° rotatable top
- Compatible with tiled floors
- Smooth body and hygienic joints
- Fully pickled/ passivated body
- Vertical (bottom) outlet pipe
- Removable silt basket

**Flow Rate:** 2.3L/sec

**Load Class:** K3 (3kN)

**Net Weight:** 6.8KG

### General Applications:

Food processing plants, commercial & industrial kitchens etc

