

GCT 125H

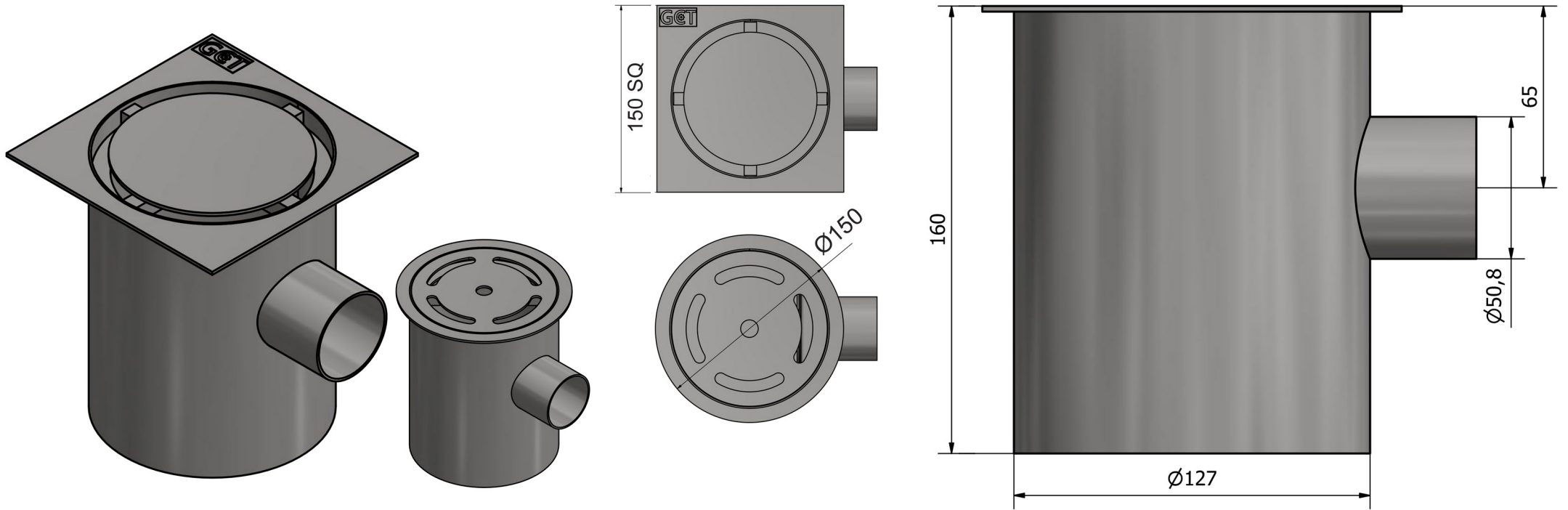

GCT 125H Floor Drain

Features

- Manufactured from 304 stainless steel (316 on special order)
- Removable tamper-proof water seal assembly
- Compatible with standard plumbing fittings
- SANS 51253-1/ EN 1253-1 compliant 50mm water seal
- Compatible with tiled and epoxy floors
- Smooth body and hygienic joints
- Fully pickled/ passivated body
- Alternative lid & flange option
- Horizontal (side) outlet pipe

Flow Rate: 1.2L/sec
Load Class: K3 (3kN)
Net Weight: 1.6KG

General Applications:

Food processing plants, commercial & industrial kitchens etc

